

# Instruction Manual

For Domestic Sewing Machine Series 5000

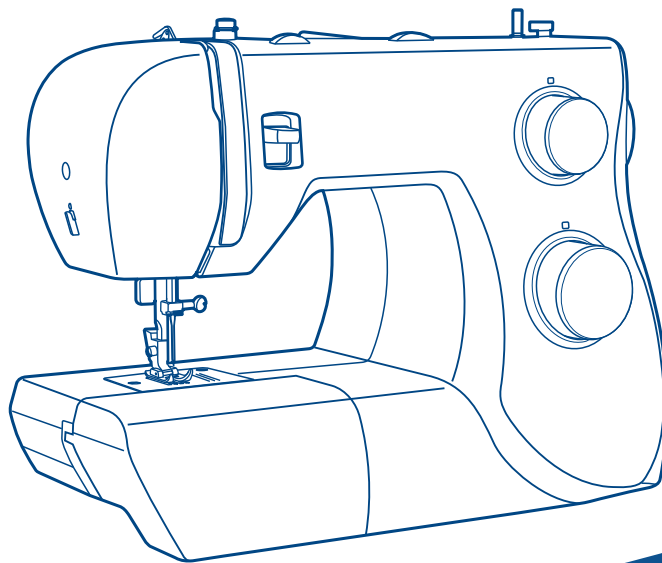



# IMPORTANT SAFETY INSTRUCTIONS

When using an electrical appliance, basic safety should always be followed, including the following:

Read all instructions before using this sewing machine.

## **DANGER** - To reduce the risk of electric shock:

1. An appliance should never be left unattended when plugged in.
2. Always unplug this appliance from the electric outlet immediately after using, as well as before cleaning and other maintenance.
3. The sewing machine is equipped with a LED lamp. If the LED lamp is broken, it must be replaced by the manufacturer or its service agent in order to avoid a hazard.

## **WARNING** - To reduce the risk of burns, fire, electric shock, or injury to persons:

1. Do not allow to be used as a toy. Close attention is necessary when this appliance is used by or near children.
2. Use this appliance only for its intended use as described in this manual. Use only attachments recommended by the manufacturer as contained in this manual.
3. Never operate this appliance if it has a damaged cord or plug, if it is not working properly, if it has been dropped or damaged, or dropped into water. Return the appliance to the nearest authorized dealer or service center for examination, repair, electrical or mechanical adjustment.
4. Never operate the appliance with any air openings block. Keep ventilation openings of the sewing machine and foot controller free from accumulation of lint, dust, and loose cloth.
5. Keep fingers away from all moving parts. Special care is required around the sewing machine needle.
6. Always use the proper needle plate. The wrong plate can cause the needle to break.
7. Do not use bent needles.
8. Do not pull or push fabric while stitching. It may deflect the needle causing it to break.
9. Switch the sewing machine off ("O") when making any adjustments in the needle area, such as threading needle, changing needle, threading bobbin, or changing presser foot, and the like.

10. Always unplug sewing machine from the electrical outlet when removing covers, lubricating, or when making any other user servicing adjustments mentioned in the instruction manual.
11. Never drop or insert any object into any opening.
12. Do not use outdoors.
13. Do not operate where aerosol spray products are being used or where oxygen is being administered.
14. To disconnect, turn all controls to the off ("O") position, then remove plug from outlet.
15. Do not unplug by pulling on cord. To unplug, grasp the plug, not the cord.
16. The sound pressure level under normal operating conditions is 75dB(A).
17. Please turn off the machine or unplug when the machine is not operating properly.
18. Never place anything on the foot controller.
19. If the supply cord that fixed with foot controller is damaged, it must be replaced by the manufacturer or its service agent or a similar qualified person in order to avoid a hazard.
20. This appliance is not intended for use by persons (including children) with reduced physical, sensory or mental capabilities, or lack of experience and knowledge, unless they have been given supervision or instruction concerning use of the appliance by a person responsible for their safety.
21. Children should be supervised to ensure that they do not play with the appliance.
22. Keep the instruction at a suitable place that close to the machine, and hand it over if you give the machine to a third party.
23. Always unplug the machine of you leave if unattended to avoid injury by expediently switch on the machine.
24. Don't use the machine in wet condition and location.

## **SAVE THESE INSTRUCTIONS**

This sewing machine is intended for household use only.

## **Congratulations:**

As the owner of a new sewing machine, you will enjoy precision quality stitching on all types of fabrics, from multiple layers of denim to delicate silks.

Your sewing machine offers the ultimate in simplicity and ease of operation. For your safety and to fully enjoy the many advantages and ease of operation of your sewing machine, we recommend that you read all the important safeguards and use and care instructions in this instruction book.

May we suggest that before you start to use your sewing machine, you discover the many features and advantages by going through this instruction book, step by step, while seated at your sewing machine.

## List of contents

Details of the machine .....	6/7	Sewing on buttons .....	27
Accessories .....	8	How to sew buttonholes (for 5205, 5209, 5311A, 5223A) .....	28
Fitting the snap-in sewing table .....	9	Sew 1-step buttonholes (for 5823A, 5832A) .....	29
Connecting machine to power source .....	10	Zippers and piping .....	30
Two-step presser foot lifter .....	11	Sewing with the Hemmer foot (optional) .....	31
Attaching the presser foot holder .....	12	3-step zig-zag .....	32
Winding the bobbin .....	13	Stitch selection .....	33
Inserting the bobbin .....	14	Smocking stitch .....	34
Inserting the needle (System 130/705H) .....	15	Sewing with the cording foot (optional) .....	35
Threading the upper thread .....	16	Darning (optional) .....	36
Automatic needle threader (5311A, 5223A, 5823A, 5832A) ....	17	Practical stitches .....	37
Thread tension .....	18	Quilting (optional) .....	38
Raising the bobbin thread .....	19	Gathering (optional) .....	39
Matching needle/ fabric/ thread .....	20	Patch work .....	40
How to choose your pattern .....	21	Applique .....	41
Stitch width dial & stitch length dial .....	22	Twin needle (optional) .....	42
Sewing straight stitch .....	23	Monogramming and embroidering with Embroidery hoop* ....	43/44
Reverse sewing/ Removing the work/ Cutting the thread .....	24	The walking foot accessory (optional) .....	45
Blind hem/ lingerie stitch (optional) .....	25	Maintenance .....	46
Overlock stitches (optional) .....	26	Trouble shooting guide .....	47

## Details of the machine

1. Thread tension dial
2. Thread take-up lever
3. Thread cutter
4. Presser foot
5. Needle plate
6. Sewing table and accessory box
7. Reverse sewing lever
8. Stitch width dial (for 5311A, 5823A, 5832A)
9. Bobbin winder stopper
10. Stitch length dial
11. Pattern selector dial
12. One step buttonhole lever (for 5823A, 5832A)
13. Automatic threader (for 5311A, 5223A, 5823A, 5832A)

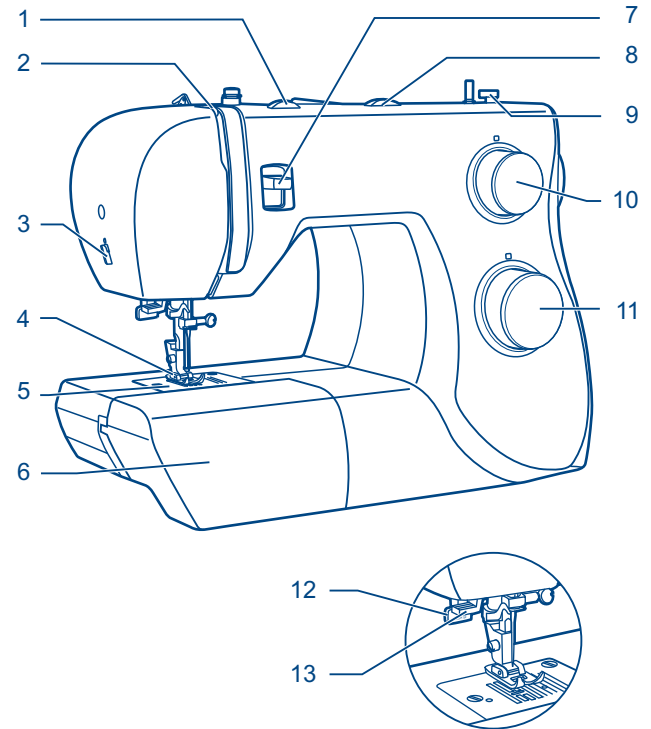

## Details of the machine

14. Horizontal spool pin
15. Bobbin winder spindle
16. Hole for second spool pin
17. Handwheel
18. Power switch
19. Main plug socket
20. Bobbin thread guide
21. Upper thread guide
22. Face plate
23. Handle
24. Presser foot lifter
25. Foot control
26. Power cord

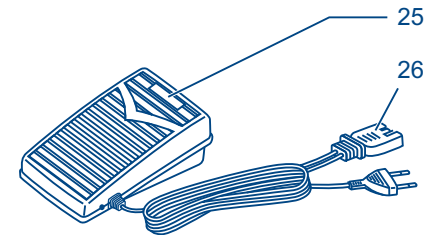
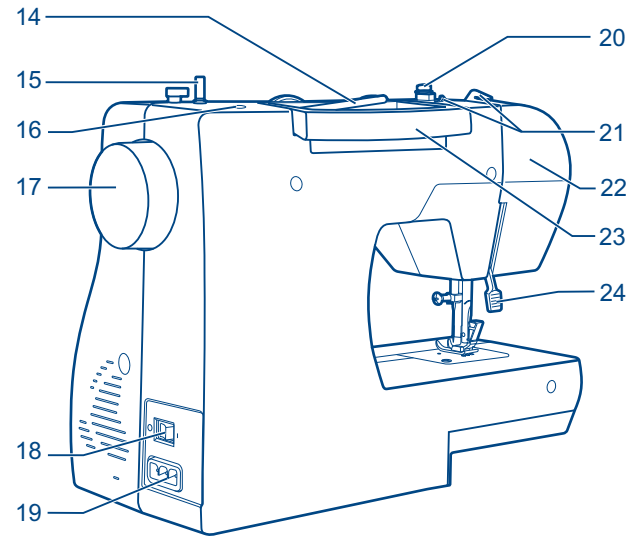

## Standard accessories (1)

- a. All purpose foot
- b. Zipper foot
- c1. Buttonhole foot (for 5205, 5209, 5311A, 5223A)
- c2. Buttonhole foot (for 5823A, 5832A)
- d. Button sewing foot
- e. Seam ripper/ brush
- f. Edge/ quilting guide
- g. Pack of needles
- h. Spool holder
- i. Bobbin (3x)
- j. L-screwdriver
- k. Oil bottle
- l. Darning plate
- m. Second spool pin
- n. Spool pin felt

## Optional accessories (2)

(These 10 accessories are not supplied with this machine; they are however available as special accessories from your local dealer.)

- o. Satin stitch foot
- p. Overcasting foot
- q. Hemmer foot
- r. Cording foot
- s. Blind hem foot
- t. Darning/ embroidery foot
- u. Gathering foot
- v. Quilting foot
- w. Walking foot

## 1 Standard accessories

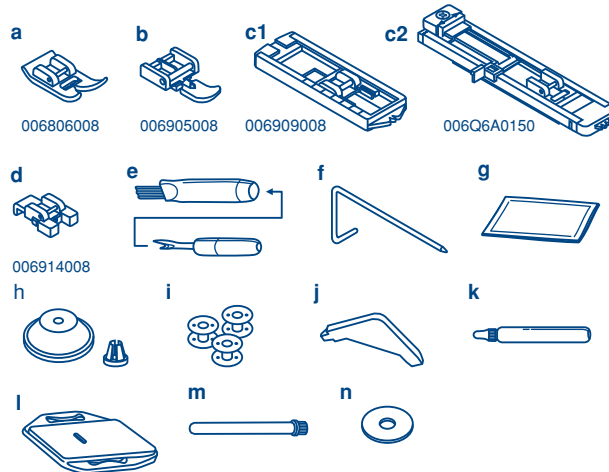

## 2 Optional accessories

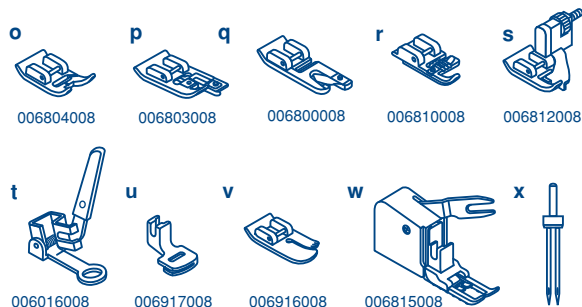



## Fitting the snap-in sewing table

Keep the snap-in sewing table horizontal, and push it in the direction of the arrow. (1)

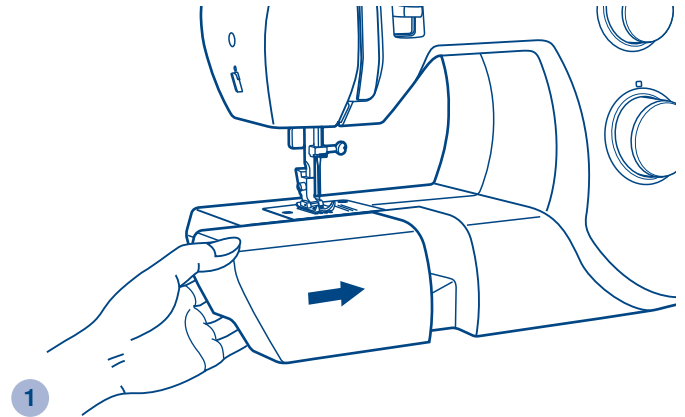

The inside of the snap-in sewing table can be utilized as an accessory box.

To open, flip cover down as shown. (2)

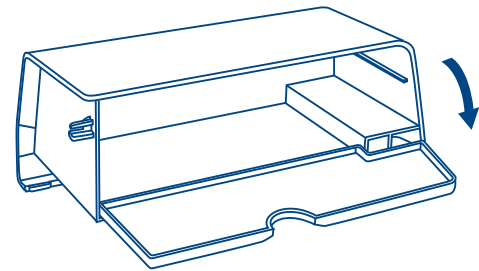

## Connecting machine to power source

Connect the machine to a power source as illustrated. (1)  
For appliance is equipped with a polarized plug which must be used with the appropriate polarized outlet. (2)

### Attention:

Unplug power cord when machine is not in use.

### Foot control

Foot control regulates the sewing speed. (3)

### Attention:

Consult a qualified electrician if in doubt as to connect machine to power source.

Unplug power cord when machine is not in use.

The appliance must be used with the foot controller KD-1902 (110-120V area)/ KD-2902 (220-240V area).

### Sewing light

Press main switch (A) for power and light on. (" I ")

### IMPORTANT NOTICE

For appliance with a polarized plug (one blade is wider than the other).

To reduce the risk of electric shock, this plug is intended to fit in a polarized outlet only one way. If it does not fit fully in the outlet, reverse the plug. If it still does not fit, contact a qualified electrician to install the proper outlet. Do not modify the plug in any way. (2)

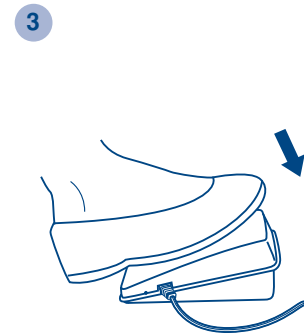
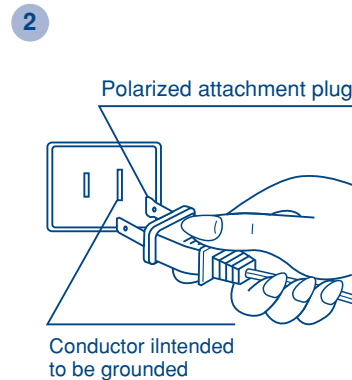
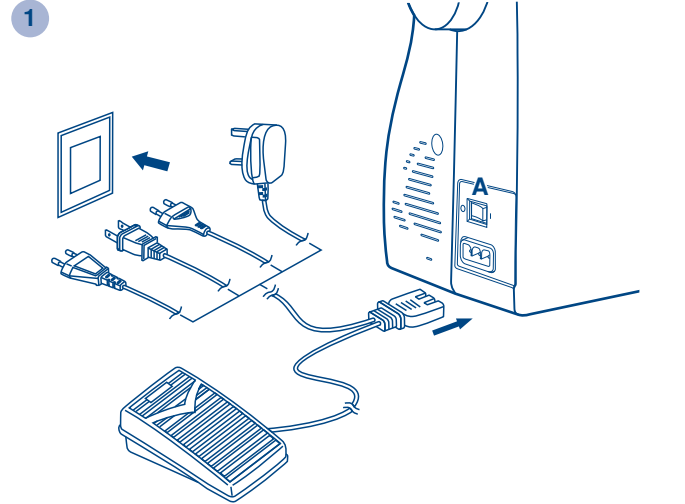

## Two-step presser foot lifter

When sewing several layers or thick fabrics, the presser foot can be raised a second stage for easy positioning of the work.  
(A)

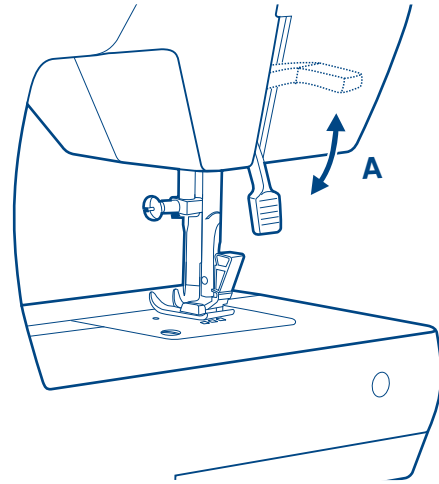

## Attaching the presser foot holder

Raise the presser clamp (a) with the presser foot lifter. Attach the presser foot holder (b) as illustrated. (1)

### Attaching the presser foot

Install the pin (d) of the presser foot (e) into the cut-out (c) of the presser foot lifter. (2)

### Removing the presser foot

Push the pin (d) of the presser foot forward to separate. (3)

### Attaching the edge/ quilting guide

Attach the edge/ quilting guide (f) in the slot as illustrated. Adjust as needed for hems, pleats, quilting, etc. (4)

#### Attention:

Turn power switch to off ("O") when carrying out any of the above operations!

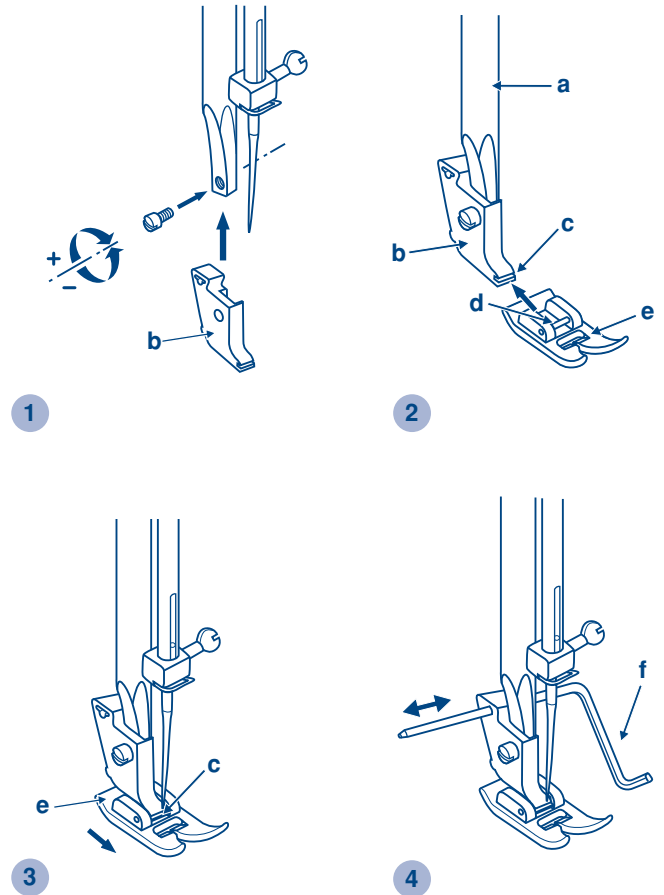

## Winding the bobbin

- Place thread and corresponding spool holder onto spool pin. (1/2)
- Snap thread into thread guide. (3)
- Wind thread clockwise around bobbin winder tension discs. (4)
- Thread bobbin as illustrated and place on spindle. (5)
- Push bobbin winder spindle to right. (6)
- Hold thread end. (7)
- Step on foot control. (8)
- Cut thread. (9)
- Push bobbin winder spindle to left (10) and remove.

### Please Note:

When the bobbin winder spindle is in "bobbin winding" position, the machine will not sew and the hand wheel will not turn. To start sewing, push the bobbin winder spindle to the left (sewing position).

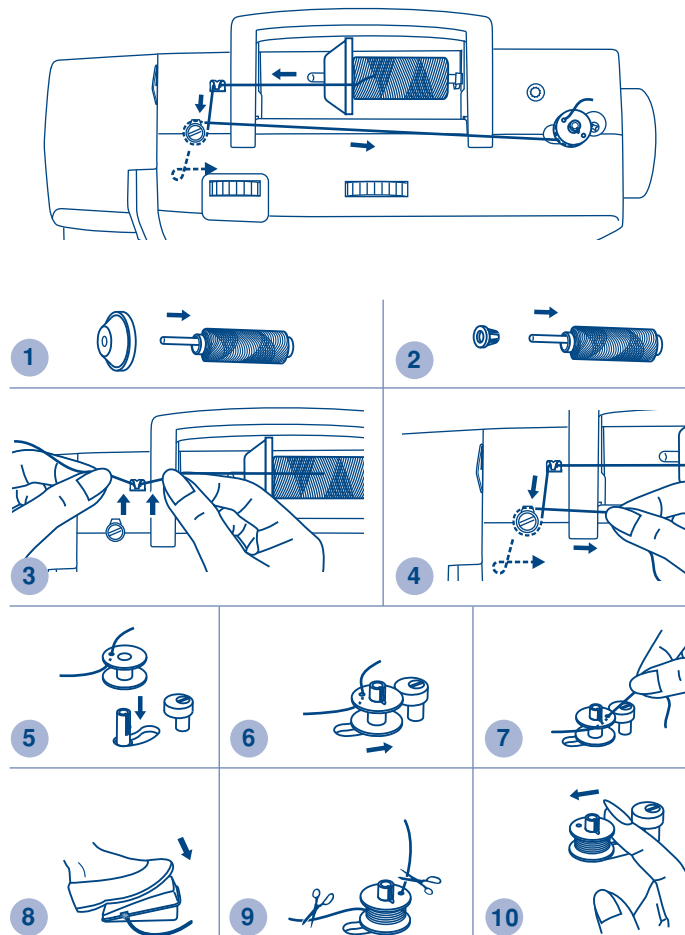

## Inserting the bobbin

When inserting or removing the bobbin, the needle must be fully raised.

- Remove the sewing table, then open the hinged cover. (1)
- Pull the bobbin case tab (a) and remove the bobbin case. (2)
- Hold the bobbin case with one hand. Insert the bobbin so that the thread runs in a clockwise direction (arrow). (3)
- Pull the thread through the slit and under the finger. (4) Leave a 6 inch tail of thread.
- Hold the bobbin case by the hinged latch. (5)
- Insert it into the shuttle. (6)

### Attention:

Turn power switch to off ("O") before inserting or removing the bobbin.

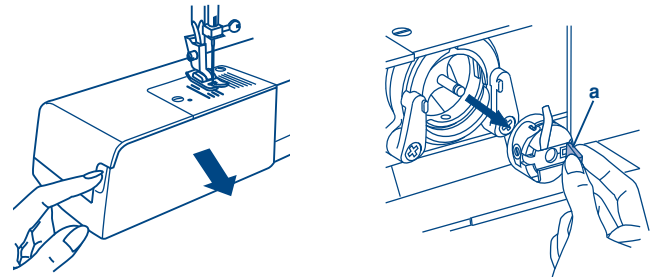

1

2

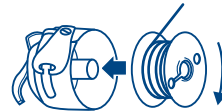

3

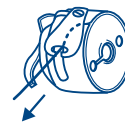

4



5

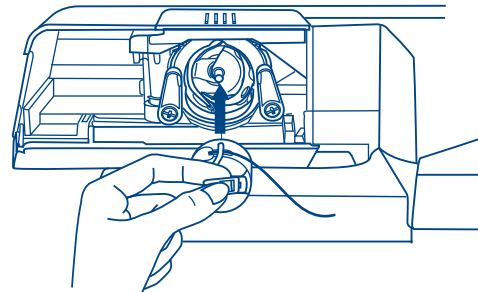

6

## Inserting the needle (System 130/705H)

Change the needle regularly, especially if it is showing signs of wear and causing problems.

Insert the needle as illustrated as follows:

- A. Loosen the needle clamp screw and tighten again after inserting the new needle. (1)
- B. The flat side of the shaft should be towards the back.
- C/D. Insert the needle as far up as it will go.

**Attention:**

Turn power switch to off ("O") before inserting or removing the needle.

Needles must be in perfect condition. (2)

Problems can occur with:

- A. Bent needles
- B. Damaged points
- C. Blunt needles

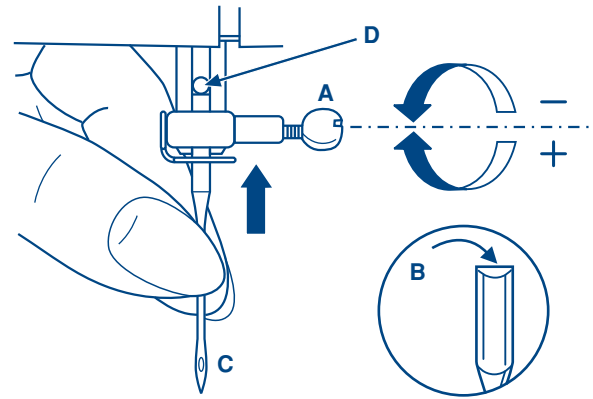

1

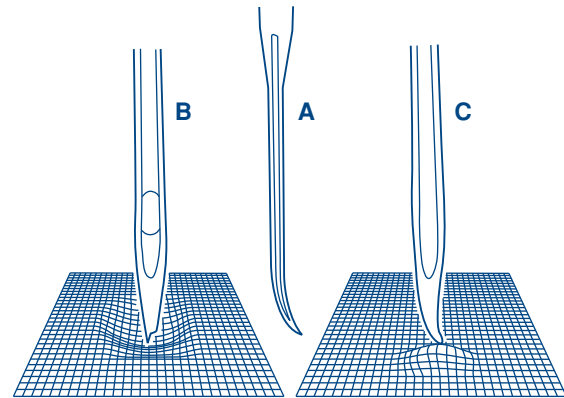

2

## Threading the upper thread

This is a simple operation but it is important to carry out correctly as by not doing so several sewing problems could result.

- Start by raising the needle to its highest point (1), and continue turning the handwheel counterclockwise until the needle just slightly begins to descend. Raise the presser foot to release the tension discs.

**Note:** For safety, it is strongly suggested you turn off the power before threading.

- Lift up the spool pin. Place the spool of thread on the holder with the thread coming off the spool as shown. For small thread spools, place small side of spool holder next to spool. (2)

- Draw thread from spool through the upper thread guide (3) and pulling thread through pre-tension spring as illustrated. (4)

- Thread tension module by leading thread down right channel and up left channel. (5) During this process it is helpful to hold the thread between the spool and thread guide.

- At the top of this movement pass thread from right to left through the slotted eye of the take-up lever and then downwards again. (6)

- Now pass thread behind the thin wire needle clamp guide (7) and then down to the needle which should be threaded from front to back.

- Pull about 6-8 inches of thread to the rear beyond the needle eye. Trim thread to length with built in thread cutter. (8)

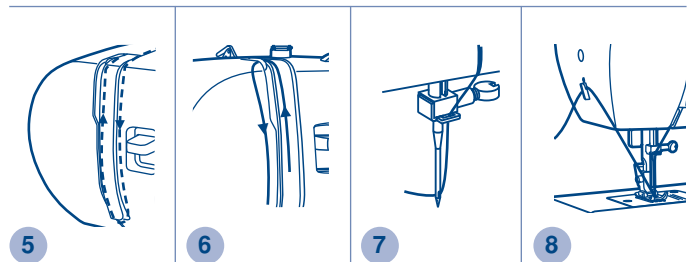
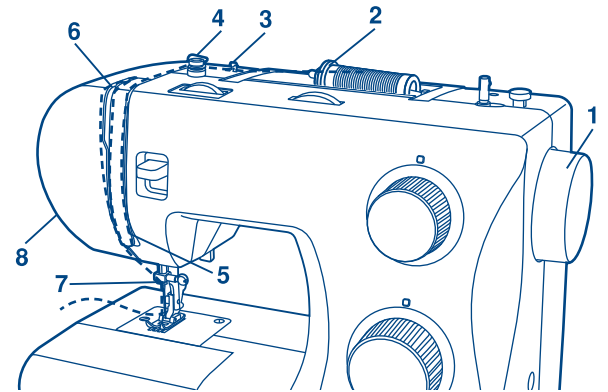
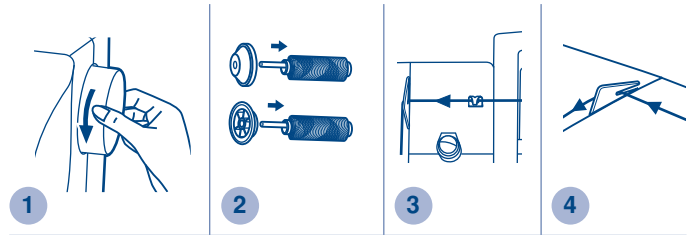

### Note:

If your sewing machine is equipped with the factory installed optional automatic needle threader, instructions for use can be found on page 16.



## Automatic needle threader (for 5311A, 5223A, 5823A, 5832A)

- Raise the needle to its highest position.
- Press lever (A) down as far as it will go.
- The threader automatically swings to the threading position (B).
- Pass thread around thread guide (C).
- Pass the thread in front of the needle around the hook (D) from bottom to top.
- Release lever (A).
- Pull the thread through the needle eye.

### Attention:

Turn power switch to off ("O")!

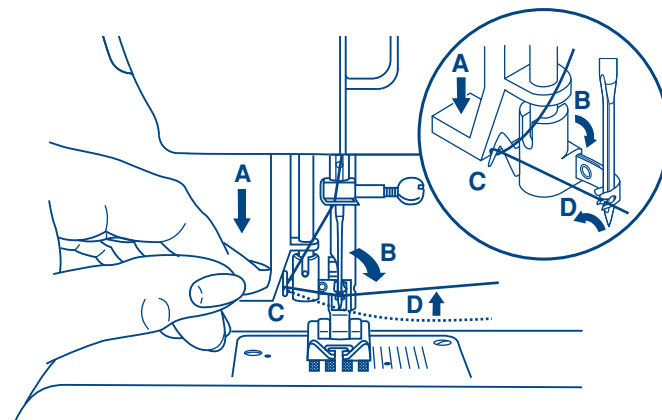

1

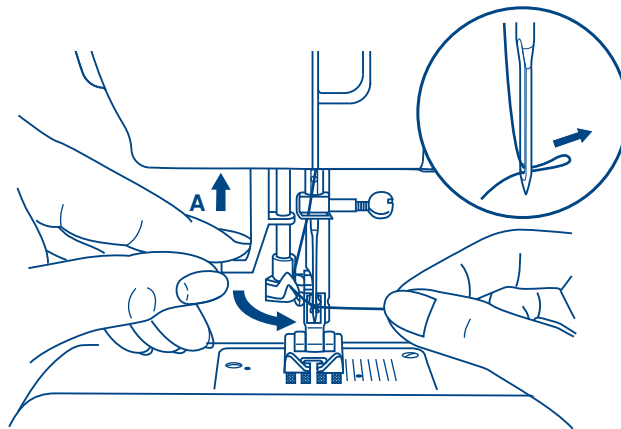

2

# Thread tension

## Upper thread tension

Basic thread tension setting: "4" (1)

To increase the tension, turn the dial to the next number up.

To reduce the tension, turn the dial to the next number down.

- A. Normal thread tension for straight stitch sewing.
- B. Thread tension too loose for straight stitch sewing. Turn dial to higher number.
- C. Thread tension too tight for straight stitch sewing. Turn dial to lower number.
- D. Normal thread tension for zig zag and decorative sewing.  
Correct thread tension is when a small amount of the upper thread appears on the bottom side of fabric.

## Lower thread tension (2)

To test the bobbin thread tension, remove the bobbin case and bobbin and hold it by the thread. Jerk it once or twice. If the tension is correct, the thread will unwind by about an inch or two. If the tension is too tight, it does not unwind at all. If the tension is too loose, it will drop too much. To adjust, turn the small screw on the side of the bobbin case.

### Please note:

- Proper setting of tension is important to good sewing.
- There is no single tension setting appropriate for all stitch functions, thread or fabric.
- A balanced tension (identical stitches both top and bottom) is usually only desirable for straight stitch construction sewing.
- 90% of all sewing will be between "3" and "5".
- For zig zag and decorative sewing stitch functions, thread tension should generally be less than for straight stitch sewing.
- For all decorative sewing you will always obtain a nicer stitch and less fabric puckering when the upper thread appears on the bottom side of your fabric.

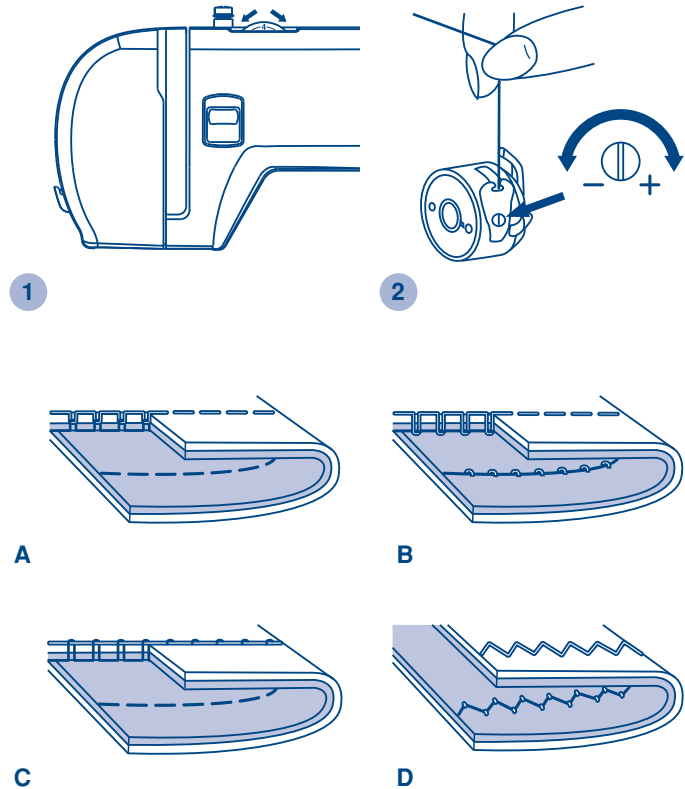

## Raising the bobbin thread

Hold the upper thread with the left hand. Turn the handwheel (1) towards you (counterclockwise) lowering, then raising needle.

**Note:**

If it is difficult to raise the bobbin thread, check to make sure the thread is not trapped by the hinged cover or the sewing table.

Gently pull on the upper thread to bring the bobbin thread up through the needle plate hole. (2)

Lay both threads to the back under the presser foot. (3)

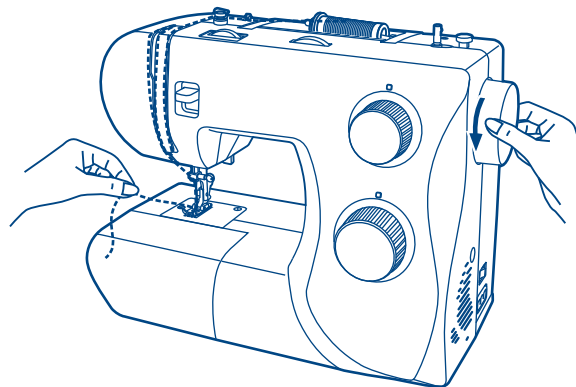

1

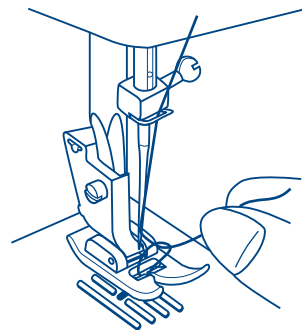

2

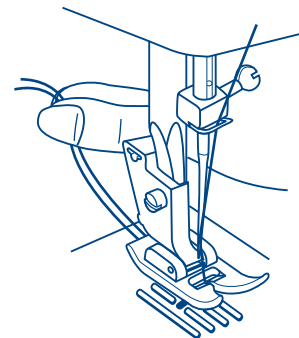

3

### NEEDLE, FABRIC, THREAD SELECTION GUIDE

NEEDLE SIZE	FABRICS	THREAD
9-11(65-75)	Lightweight fabrics-thin cottons, voile, serge, silk, muslin, Qiana, interlocks, cotton knits, tricot, jerseys, crepes, woven polyester, shirt & blouse fabrics.	Light-duty thread in cotton, nylon or polyester.
12(80)	Medium weight fabrics-cotton, satin, kettleclote, sailcloth, double knits, lightweight woollens.	Most threads sold are medium size and suitable for these fabrics and needle sizes. Use polyester threads on synthetic materials and cotton on natural woven fabrics for best results. Always use the same thread on top and bottom.
14(90)	Medium weight fabrics-cotton duck, woolen, heavier knits, terrycloth, denims.	
16(100)	Heavyweight fabrics-canvas, woollens, outdoor tent and quilted fabrics, denims, upholstery material (light to medium).	
18(110)	Heavy woollens, overcoat fabrics, upholstery fabrics, some leathers and vinyls.	Heavy duty thread, carpet thread. (Use heavy foot pressure-large numbers.)

**IMPORTANT:** Match needle size to thread size and weight of fabric

### NEEDLE, FABRIC SELECTION

NEEDLES	EXPLANATION	TYPE OF FABRIC
HAx1 15x1	Standard sharp needles. Sizes range thin to large. 9 (65) to 18(110)	Natural woven fabrics-wool, cotton, silk, etc. Qiana. Not recommended for double knits.
15x1/705H(SUK)	Semi-ball point needle, scarfed. 9(65) to 18(110)	Natural and synthetic woven fabrics, polyester blends. Knits-polyesters, interlocks, tricot, single and double knits. Can be used instead of 15x1 for sewing all fabrics.
15x1/705H(SUK)	Full ball point needle 9(65) to 18(110)	Sweater knits, Lycra, swimsuit fabric, elastic.
130 PCL	Leather needles. 12(80) to 18(110)	Leather, vinyl, upholstery. (Leaves smaller hole than standard large needle.)

- Note:**
1. Twin needles, can be purchased for utility and decorative work.
  2. When sewing with twin needles, the stitch width dial should be set at less than "3".
  3. European needles show sizes 65, 70, 80 etc. American and Japanese needles show size 9, 11, 12 etc.
  4. Replace needle often (approximately every other garment ) and / or at first thread breakage or skipped stitches.

## How to choose your pattern

To select a stitch, simply turn the pattern selector dial. The pattern selector dial may be turned in either direction.

For **straight stitch**, select pattern "1" or "2" with the pattern selector dial. Adjust the stitch length with the stitch length dial.

For **zigzag stitch**, select pattern "3" or "4" with the pattern selector dial. Adjust the stitch length and stitch width according to the fabric being used.

To obtain the other patterns, turn the stitch length dial to "S1" or "S2", select the pattern desired with pattern selector dial, and adjust the stitch width with the stitch width dial. (for 5311A, 5823A, 5832A)

Please consult the following stitch patterns chart.

- a. Reverse lever
- b. Stitch width dial (for 5311A, 5823A, 5832A)
- c. Stitch length dial
- d. Pattern selector dial

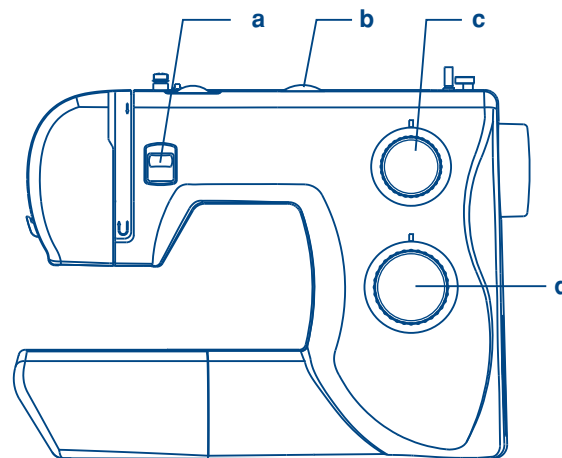

## Stitch width dial & stitch length dial

### Function of stitch width dial

The maximum zigzag stitch width for zigzag stitching is 5mm; however, the width can be reduced on any patterns. The width increases as you move stitch width dial from "0" - "5". (1)

The Stitch width dial is also the control for the straight stitch infinite needle position. "0" position is center and "5" is full left needle position (for 5823A, 5832A), "0" position is center and "5" is full right needle position (for 5311A).

### Function of stitch length dial while zig-zag stitching

Set the pattern selector dial to zig-zag.

The density of zig-zag stitches increase as the setting of stitch length dial approaches "0".

**Neat zig-zag stitches are usually achieved at "2.5" or below.**  
(2)

### Function of stitch length dial for straight stitching

For straight stitch sewing, turn the pattern selector dial to the straight stitch setting. Turn the stitch length dial, and the length of the individual stitches will decrease as the dial approaches "0". The length of the individual stitches will increase as the dial approaches "4". (3) Generally speaking, use a longer stitch length when sewing heavier weight fabrics or when using a thicker needle or thread. Use a shorter stitch length when sewing lighter weight fabrics or when using a finer needle or thread.

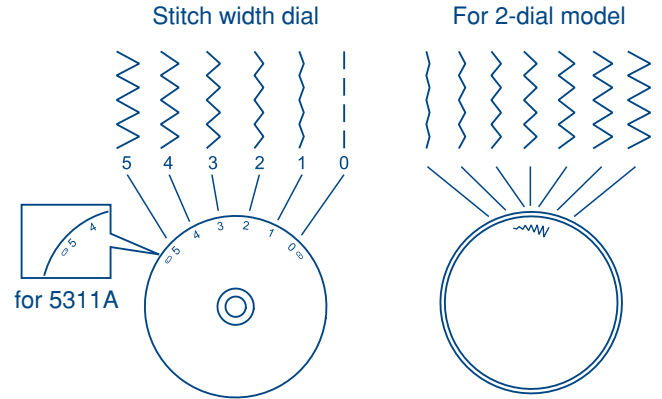

1

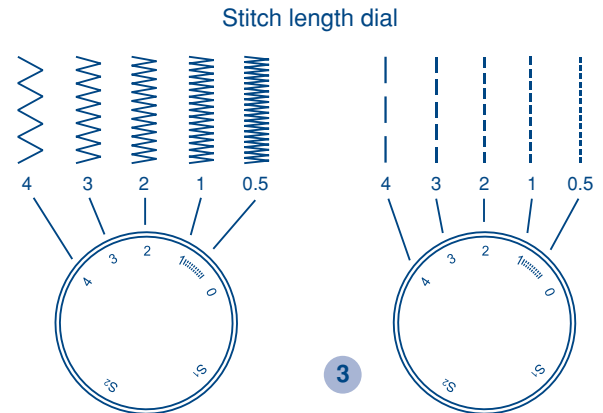

2

3

## Sewing straight stitch

To begin sewing, set the machine for straight stitch. (1)

Place the fabric under the presser foot with the fabric edge lined up with the desired seam guide line on the needle plate. (2)

Lower the presser foot lifter, and then step on the foot controller to start sewing. (3)

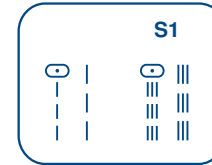

1

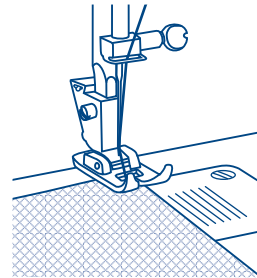

2

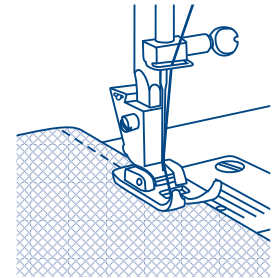

3

## Reverse sewing

To secure the beginning and the end of a seam, press down the reverse sewing lever (A). Sew a few reverse stitches. Release the lever and the machine will sew forward again. (1)

## Removing the work

Turn the handwheel toward you (counterclockwise) to bring the thread take up lever to its highest position, raise the presser foot and remove work behind the needle and presser foot. (2)

## Cutting the thread

Pull the threads under and behind the presser foot. Guide the threads to the side of the face plate and into thread cutter (B). Pull threads down to cut. (3)

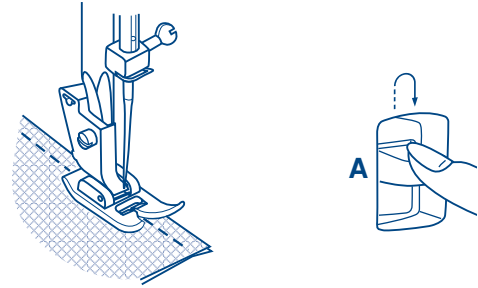

1

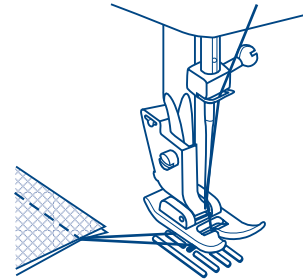

2

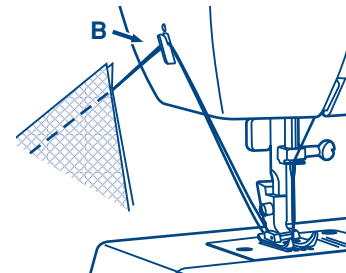

3



## Blind hem/ lingerie stitch

\* The blind hem foot is an optional accessory not supplied with your machine.

For hems, curtains, trousers, skirts, etc.

~~~~~ Blind hem for stretch fabrics.

..A..A.. Blind hem/ lingerie for firm fabrics.

Set the machine as illustrated.

### Note:

It takes practice to sew blind hems. Always make a sewing test first.

Fold the fabric as illustrated with the wrong side uppermost. (1)  
Place the fabric under the foot. Turn the handwheel forwards by hand until the needle swings fully to the left. It should just pierce the fold of the fabric. If it does not, adjust the stitch width accordingly. (2)

Adjust the guide (3) by turning the knob (4) so that the guide just rests against the fold.

Sew slowly, by pressing the foot control lightly guiding the fabric along the edge of the guide.

Stitch width dial

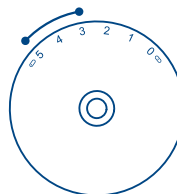

Stitch length dial

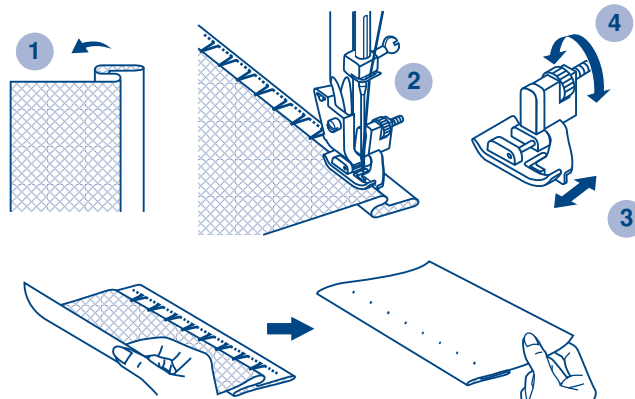
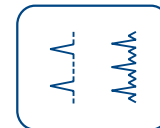
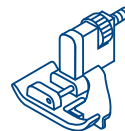
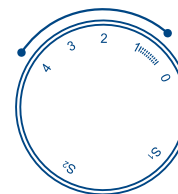

## Overlock stitches

\* The overcasting foot is an optional accessory not supplied with your machine.

Seams, neatening, visible hems.

Turn stitch length dial to "S1" or "S2", The stitch width can be adjusted to suit the fabric.

**Stretch overlock:** 

For fine knits, jerseys, neck edges, ribbing. (1)

**Standard overlock:** 

For fine knits, jerseys, neck edges, ribbing. (2)

**Double overlock stitch:** 

For fine knits, handknits, seams. (3)

All overlock stitches are suitable for sewing and neatening edges and visible seams in one operation.

When neatening, the needle should just go over the edge of the fabric.

### Attention:

Use new needles or ball point needles or stretch needle!

Stitch width dial

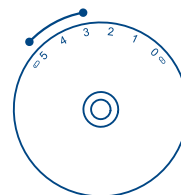

Stitch length dial

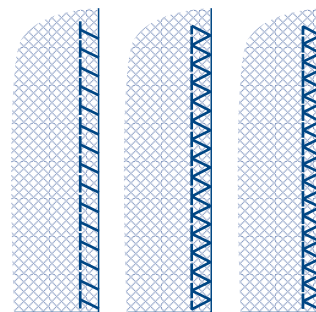
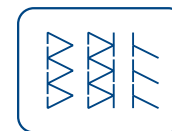
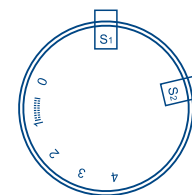

1

2

3

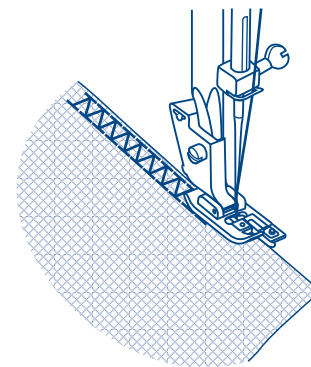

## Sewing on buttons

Install the darning plate. (1)

Change presser foot to button sewing foot.

Position the work under the foot. Place the button on the marked position and lower the foot. Set the pattern selector knob on "0" and sew a few securing stitches. Select the zig-zag stitch width according to the distance between the two holes of the button. Turn the handwheel to check if the needle goes into the right and the left hole of the button without any obstruction (adjust the stitch width according to the button). Slowly sew on the button with about 10 stitches. Select pattern "0" and sew a few securing stitches. (2) (for 5205, 5209, 5223A)

Position the work under the foot. Place the button in the desired position, lower the foot. Set the pattern selector knob on zig zag stitch "Z". Adjust the stitch width to "3" - "5" according to the distance between the two holes of the button. Turn the handwheel to check that the needle goes cleanly into the left and right holes of the button. Set the pattern selector knob on straight stitch "1", and sew a few securing stitches. Set the pattern selector knob on zig zag stitch "Z", and slowly sew on the button with about 10 stitches. Set the pattern selector knob on straight stitch "1", and sew a few securing stitches. (2) (for 5311A, 5823A, 5832A)

If a shank is required, place a darning needle on top of the button and sew. (3) For buttons with 4 holes, sew through the front two holes first (2), push work forward and then sew through the back two holes as described. (3)

Stitch width dial

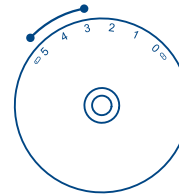

Stitch length dial

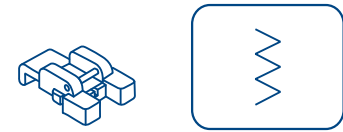
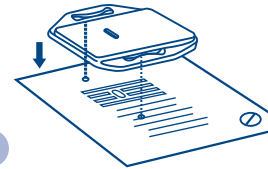
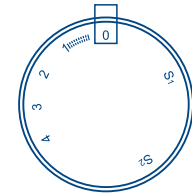

1

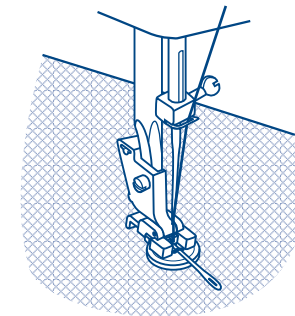
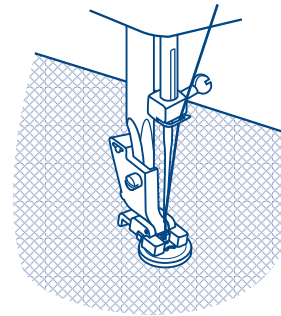

2

3

## How to sew buttonholes (for 5205, 5209, 5311A, 5223A)

### Prepare

Set the stitch pattern dial to " ".

1. Take off the all purpose foot and attach the buttonhole foot.
2. Measure diameter and thickness of button and add 0.3 cm (1/8") for bar tacks; mark buttonhole size on fabric.
3. Place fabric under the foot, so that mark on the buttonhole foot lines up with the marking on the fabric. Lower the foot, so that the center line of the fabric buttonhole comes to the center of the foot hole.

Adjust the stitch length dial in the "0.5-1" to set stitch density.  
**Note:** density varies according to the fabric. Always test sew a buttonhole.

Follow the 4-step sequence changing from one step to another (1-4) with the stitch pattern selector dial. Take care not to sew too many stitches in stages 1 and 3. Use seam ripper and cut buttonhole open from both ends towards the middle.

### Tips :

- Slightly reduce upper thread tension to produce better results.
- Use a backing for fine or stretchy fabrics.
- It is advisable to use heavy thread or cord for stretch or knit fabrics.
- The zig-zag should sew over the heavy thread or cord. (5)

Stitch width dial

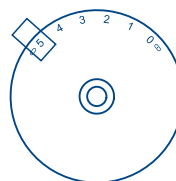

Stitch length dial

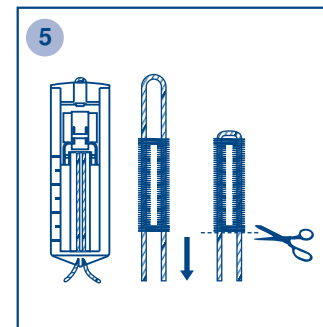
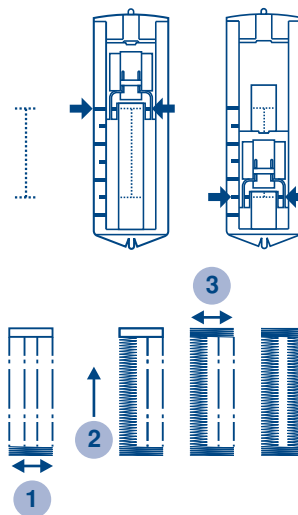
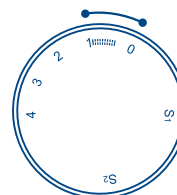

## Sew 1-step buttonholes (for 5823A, 5832A)

**Buttonhole sewing is a simple process that provides reliable results. However, it is strongly suggested to always make a practice buttonhole on a sample of your fabric and stabilizer.**

### Making a Buttonhole

1. Using tailor's chalk, mark the position of the buttonhole on the fabric.
2. Attach the buttonhole foot and set the Pattern Selector Dial to "1".  
Set stitch length dial to "0". Set the stitch width at "5". The width however may need to be adjusted according to the project, Sew a test first to determine this.
3. Lower the presser foot aligning the marks on foot with the marks on the fabric (1). (The front bar tack will be sewn first.) (Align the mark on the fabric (a) with the mark on the foot (b).)
4. Open the button plate and insert the button (2).
5. Lower the buttonhole lever and gently push it back (3).
6. While lightly holding the upper thread, start the machine.
7. Buttonhole stitching is done in the order (4).
8. Stop the machine when the buttonhole cycle has completed.

### Making a Buttonhole on Stretch Fabrics (5)

When sewing buttonholes on stretch fabric, hook heavy thread or cord under the buttonhole foot. When the buttonhole is sewn the legs will overcast the cord.

1. Mark the position of the buttonhole on the fabric with the tailor's chalk, attach the buttonhole foot, and set the pattern selector dial to "1". Set stitch length dial to "0".
2. Hook the heavy thread under the back end of the buttonhole foot, then bring the two heavy thread ends to the front of the foot, insert them into the grooves and temporarily tie them there.
3. Lower the presser foot and start sewing.  
\*Set the stitch width to match the diameter of the gimp thread.
4. Once sewing is completed, gently pull the heavy thread to remove any slack, then trim off the excess.

Stitch width dial

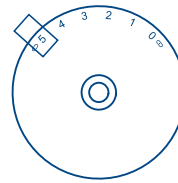

Stitch length dial

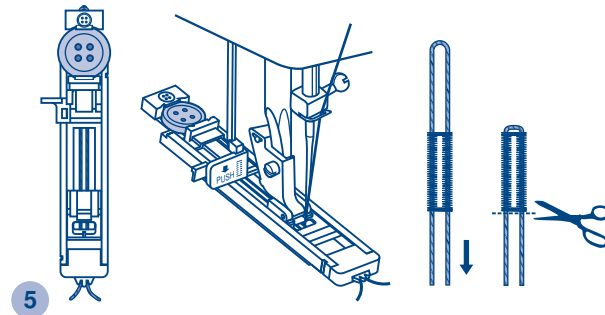
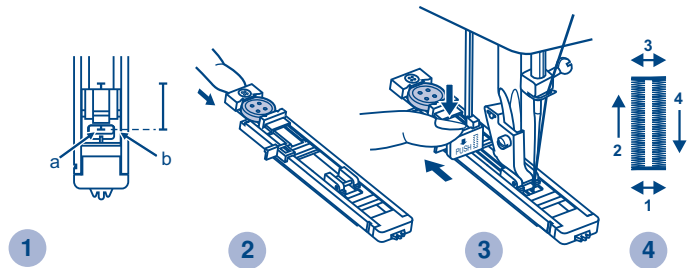
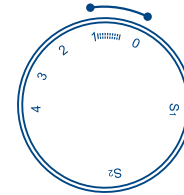

## Zippers and piping

Set the machine as illustrated.

The zip foot can be inserted right or left, depending on which side of the foot you are going to sew. (1)

To sew past the zip pull, lower the needle into the fabric, raise the presser foot and push the zip pull behind the presser foot. Lower the foot and continue to sew.

It is also possible to sew in a length of cord, into a bias strip to form a 'welt'.(2)

Set stitch length dial between "1" - "4" (according to thickness of fabric).

Stitch width dial

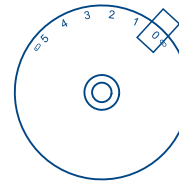

Stitch length dial

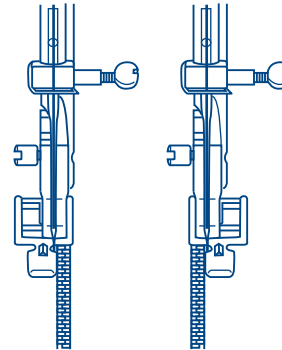
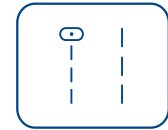
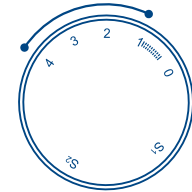

1

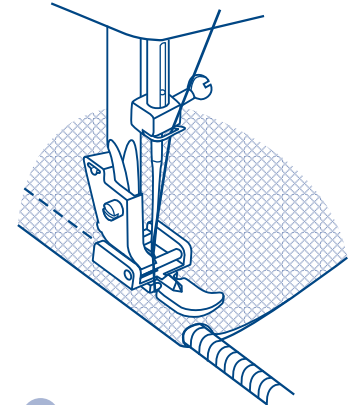

2

## Sewing with the Hemmer foot (optional)

\* The hemmer foot is an optional accessory not supplied with your machine.

For hems in fine or sheer fabrics.

Set the machine as illustrated.

Neaten the edge of the fabric. At the beginning of the hem, turn under the edge twice by about 3mm (1/8") and sew 4-5 stitches to secure. Pull the thread slightly towards the back. Insert the needle into the fabric, raise the presser foot and guide the fold into the scroll on the foot. (1)

Gently pull the fabric edge towards you and lower the presser foot. Begin sewing, guiding the fabric into the scroll by holding it upright and slightly to the left. (2)

Stitch width dial

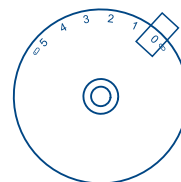

Stitch length dial

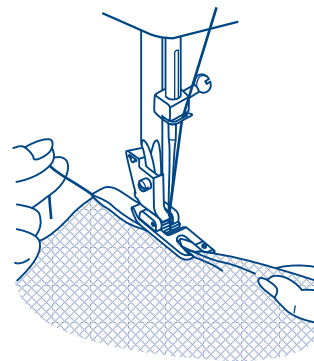
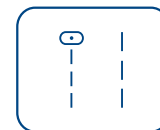
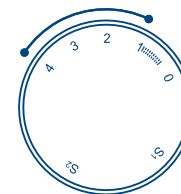

1

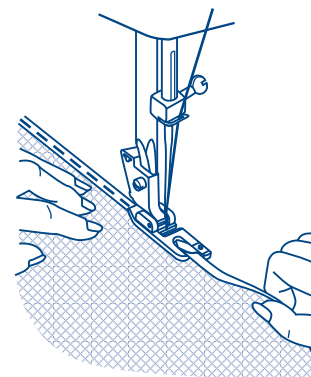

2

## 3-step zig-zag

Sewing on lace and elastic, darning, mending, reinforcing edges.

Set the machine as illustrated.

Place patch in position. The stitch length can be shortened to produce very close stitches. (1)

When mending tears, it is advisable to use a piece of backing fabric to reinforce. The stitch density can be varied by adjusting the stitch length. First sew over the center and then overlap on both sides. Depending on the type of fabric and damage, sew between 3 and 5 rows. (2)

### Sewing elastic

1. Place the elastic on the fabric.
2. As you sew, stretch the elastic both in the front and behind the presser foot as shown in fig. (3)

### Joining fabric

The elastic stitch can be used to join two pieces of fabric together and is very effective when sewing knitted fabrics. If nylon thread is used, the stitch will not be visible.

1. Place the edges of the two pieces of fabric together and center them under the presser foot.
2. Sew them together using the elastic stitch taking care to keep the two fabric edges close together as shown in fig. (4)

Stitch width dial

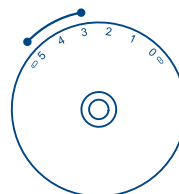

Stitch length dial

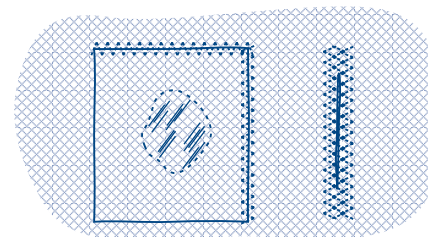
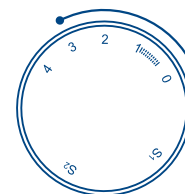

1

2

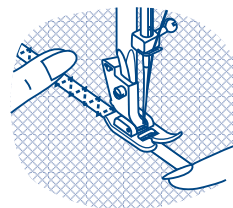

3

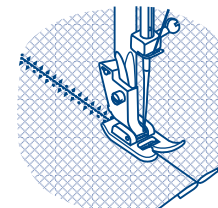

4



## Stitch selection

### Triple straight stitch: (1)

For hardwearing seams.

Turn the stitch length dial to "S1" or "S2".

The machine sews two stitches forwards and one stitch backwards. This gives triple reinforcement.

Stitch width dial

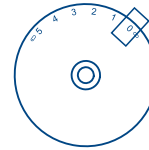

Stitch length dial

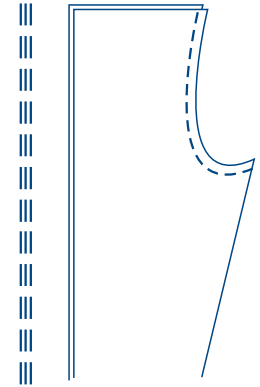
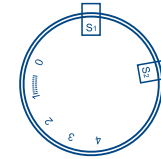

1

### Triple zig-zag: (2)

For hardwearing seams, hems and decorative seams.

Turn the stitch length dial to "S1" or "S2".

Adjust the stitch width dial to between "3" and "5".

Triple zig-zag is suitable for firm fabrics like denim, corduroy, etc.

Stitch width dial

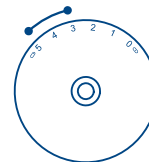

Stitch length dial

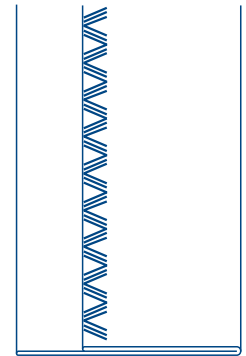
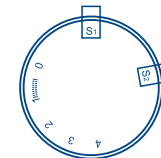

2

## Smocking stitch

Seams, hems, T-shirts, underwear, etc.

Set the machine as illustrated.

This stitch can be used for all types of jersey as well as for woven fabrics. (1)

Sew at 1cm (1/4") from the fabric edge and trim the surplus fabric. (2)

Stitch width dial

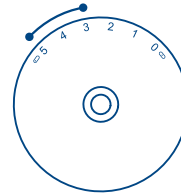

Stitch length dial

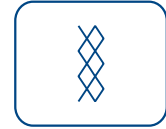
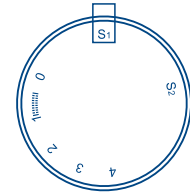

1

2

## Sewing with the cording foot (optional)

\* The cording foot is an optional accessory not supplied with your machine.

Decorative effects, cushions, tablecloths, etc.

Set the machine as illustrated.

Various stitches are suitable for sewing on cord, e.g. Zig-zag, Triple zig-zag, decorative stitches.

Insert the cord between the spring covering the cord groove and the foot. The cord should run in the groove. One, two or three cords can be sewn on. The stitch width is adjusted according to the number of cords and the stitch selected. (1/2)

Stitch width dial

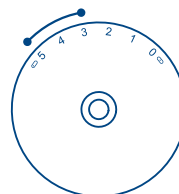

Stitch length dial

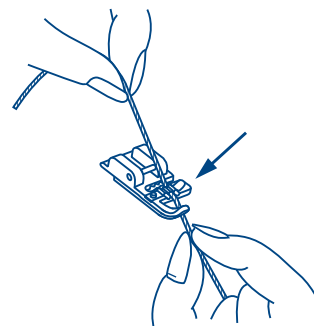
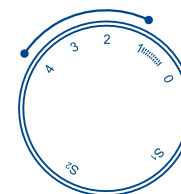

1

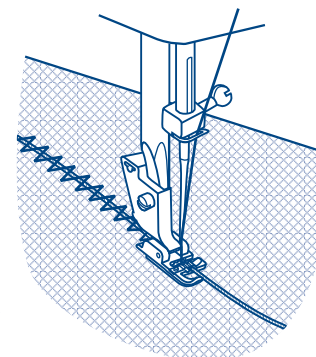

2

## Darning (optional)

\* The darning/ embroidery foot is an optional accessory not supplied with your machine.

Set the machine as illustrated.

Install the darning plate. (1)

Remove the presser foot clamp. (2)

Attach the darning foot to the presser foot holder. The lever (a) should be behind the needle clamp screw (b). Press the darning foot on firmly from behind with your index finger and tighten the screw (c). (3)

First sew round the edge of the hole (to secure the threads). (4)  
First row: Always work from left to right. Turn work by 1/4 and oversew.

A darning ring is recommended for easier sewing and better results.

Stitch width dial

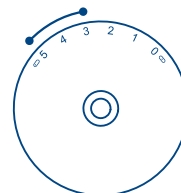

Stitch length dial

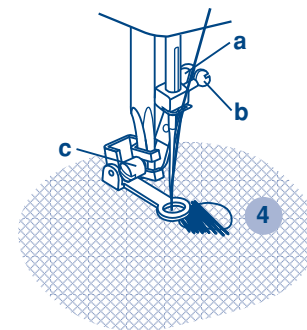
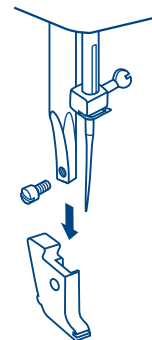
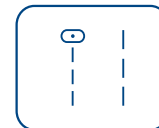
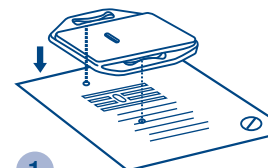
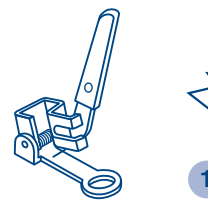
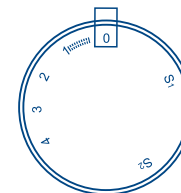

## Practical stitches

Set the machine as illustrated.

### Shell hem (1)

For decorative edges.

Suitable for edges on sheer, fine and stretch fabrics. The larger stitch should go just over the edge of the fabric to create the shell effect.

- This stitch requires a tighter thread tension than normal.
- Place the fabric under the presser foot so that it will be sewn along the bias with the straight stitches sewn on the seamline and the zigzag stitches sewn slightly over the folded edge.
- Sew at a slow speed.

### Rampart (2)

For flat joining seams, sewing on elastic, visible hems.

This stitch can be used for firm, thicker fabrics.

### Bridging (3)

For seams, place mats, tablecloths.

Decorative joining seam for a fagoted effect. Gathering with cord or shirring elastic.

Stitch width dial

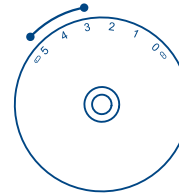

Stitch length dial

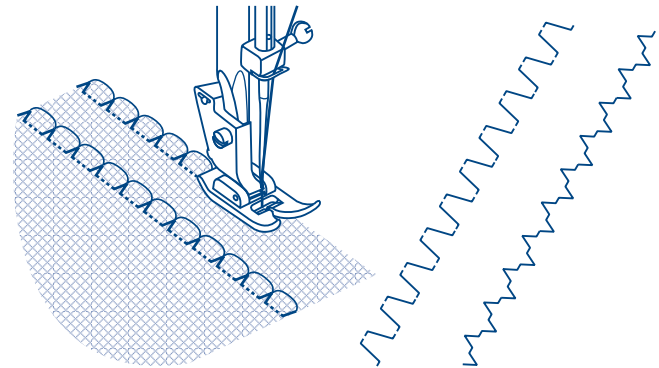
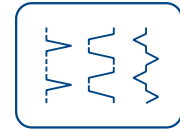
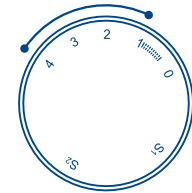

1

2

3

## Quilting (optional)

\* The quilting foot is an optional accessory not supplied with this machine.

Set the machine as illustrated.

Insert the edge/quilting guide in presser foot holder and set the space as you desired.

Move the fabric over and sew successive rows with the guide riding along on the previous row of stitching.

Stitch width dial

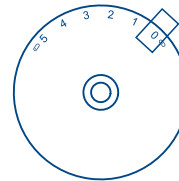

Stitch length dial

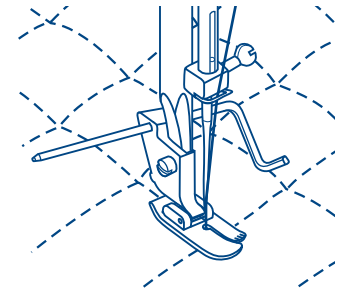
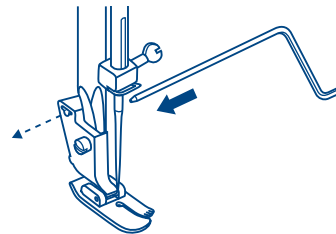
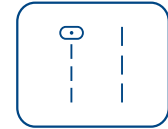
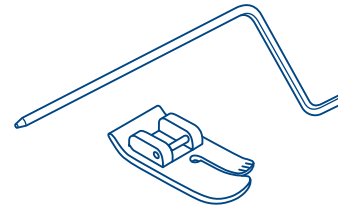
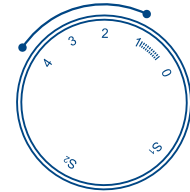

## Gathering (optional)

\* The gathering foot is an optional accessory not supplied with this machine.

Set the Pattern Selector as illustrated.

1. Attach the gathering foot.
2. Sew a single row or multiple rows of straight stitches.
3. If more gathering in required, loosen the upper thread (to about 2) so that the lower thread lies on the under side of the material.
4. Pull the lower thread to gather more of the material.

Stitch width dial

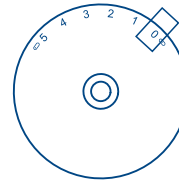

Stitch length dial

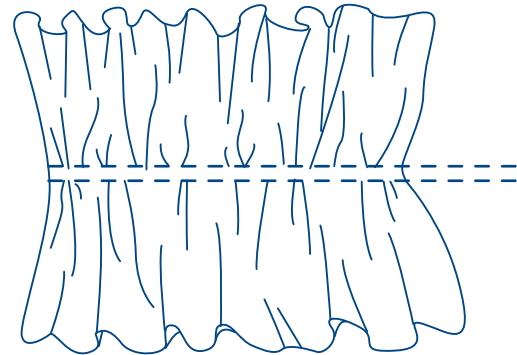
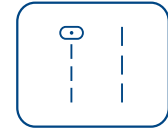
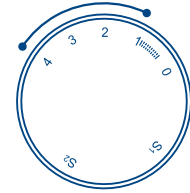

## Patch work

These stitches are used to join two pieces of fabric while leaving a space between their edges.

1. Fold over the edges of the two pieces of fabric for the hem and baste the edges to a thin piece of paper leaving a small space between them.
2. Set the Pattern selector as illustrated. Turn the stitch length dial to "S1".
3. Stitch along the edge, pulling both threads slightly when beginning to sew.
  - \* Use thicker than normal threads for sewing.
4. After sewing, remove the basting and the paper. Finish by tying knots on the reverse side at the beginning and the end of the seams.

Stitch width dial

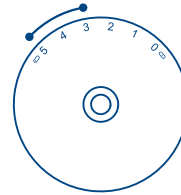

Stitch length dial

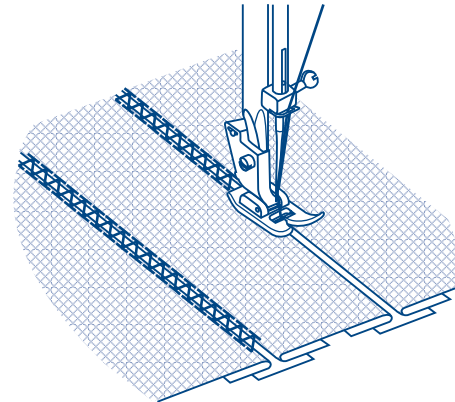
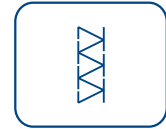
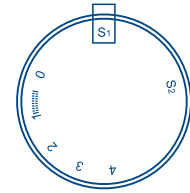



# Applique

- Turn stitch length dial to the desired length.
- Turn pattern selector dial to small zig zag width.
- Cut out the applique design and baste it to the fabric.
- Sew slowly around the edge of the design.
- Trim excess material outside the stitching. Make sure not to cut any stitches.
- Remove the basting thread.
- Tie top and bottom thread under the applique to avoid unraveling.

Stitch width dial

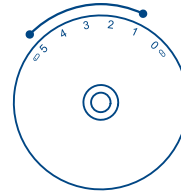

Stitch length dial

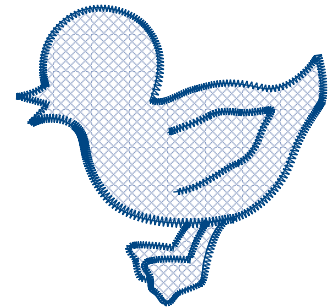
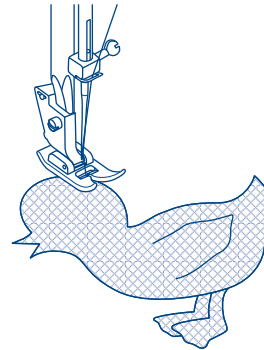
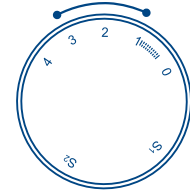

## Twin needle (optional)

- Turn stitch length dial to the desired stitch length.
- Turn stitch selector to straight stitch, center needle position.
- For twin needle sewing, insert the extra spool pin into the hole on top of the machine.
- Make sure that the two threads used to thread the twin needle are of the same weight. You can use one or two colors.
- Insert the twin needle in the same way as single needle. Flat side of needle should face away from you.
- Follow instructions for single needle threading. Thread each needle separately.

### Please note:

When sewing with twin needle, always proceed slowly, and make sure to maintain a low speed to insure quality stitching.

When using twin needle on zig-zag make sure the stitch width dial is set between "0" and "3". Do not use twin needle at setting above "3" (for 5311A, 5823A, 5832A).

Stitch width dial

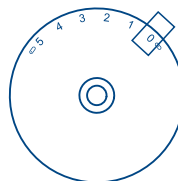

Stitch length dial

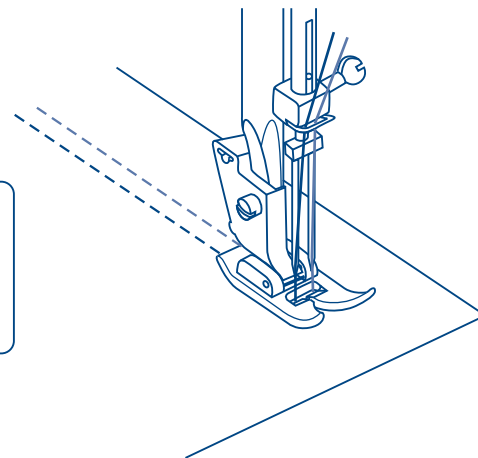
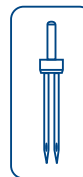
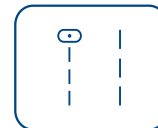
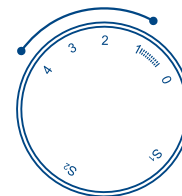

## Monogramming and embroidering with embroidery hoop\*

### Preparation for Monogramming and Embroidering\*

- Draw the desired lettering or design on the right side of the fabric.
- Stretch the fabric between embroidery hoop as firmly as possible.
- Place the fabric under the needle. Make sure the presser foot bar is down in its lowest position.
- Turn the balance wheel towards you to bring up the lower thread through the fabric. Sew a few securing stitches at the starting point.
- Hold the hoop with thumb and forefingers of both hands while pressing the material with the middle and third fingers and supporting the outside of hoop with smaller finger.

\* Embroidery hoop not included with machine.

Stitch width dial

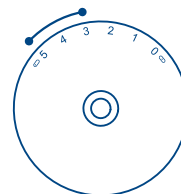

Stitch length dial

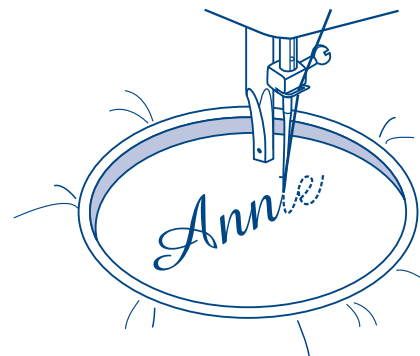
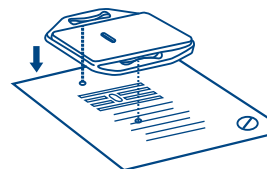
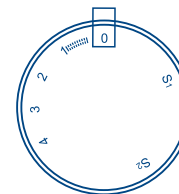

### Monogramming

1. Sew, moving the hoop slowly along the lettering at a constant speed.
2. Secure with a few straight stitches at the end of the last letter.

### Embroidering

1. Stitch the outline of the design by moving the embroidery hoop.
2. Fill in the design working from the outline of the design to the inside and from the inside to the edge of the outline until the design is completely filled in. Keep the stitching close together.

\* A long stitch is made by moving the hoop rapidly and a short stitch is made by moving it slowly.

3. Secure with a few Straight Stitches at the end of the design.

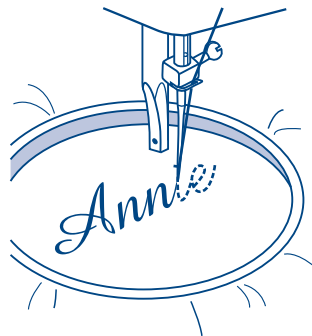

1

Annie

2

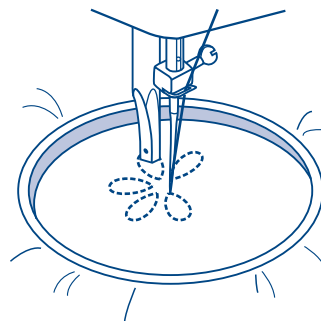

3

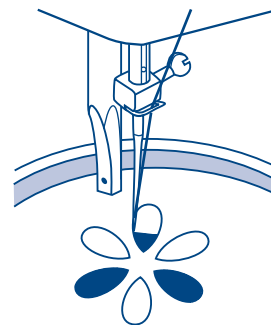

4

## The walking foot accessory

\* The walking foot accessory is optional. It is not included with this machine.

Always try to sew first without the walking foot accessory which should be used only when necessary.

It is easier to guide the fabric and you have a better view of the seam when using the standard, regular foot on your machine. Your sewing machine offers excellent stitch quality on a wide range of fabrics from delicate chiffons to multiple layers of denim.

The "Walking foot" accessory equalizes the feeding of the upper and lower layers of fabric and improves the matching of plaids, stripes and patterns. This foot helps to prevent uneven feeding of very difficult fabrics.

1. Lift the presser foot bar.
2. Remove the "foot holder" by opening counter clockwise the presser bar attaching screw. (3)
3. Attach the "walking foot" to the machine in the following way.
  - i) The fork arm should fit into the needle screw and clamp. (2)
  - ii) Slide the plastic "attaching head" from your left to right so that it is fitted into the "presser foot bar".
  - iii) Lower the "presser foot bar".
  - iv) Replace and tighten clockwise the "presser bar attaching screw".
4. Make sure both the "needle screw" and the "presser bar attaching screw" are tightly secured.
5. Draw the bobbin thread up and place both the bobbin thread and the needle thread behind the walking foot attachment.

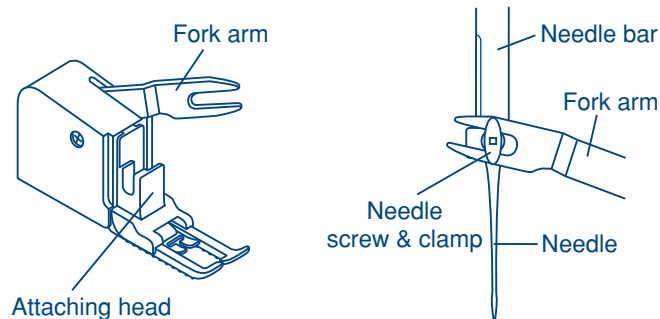

1

2

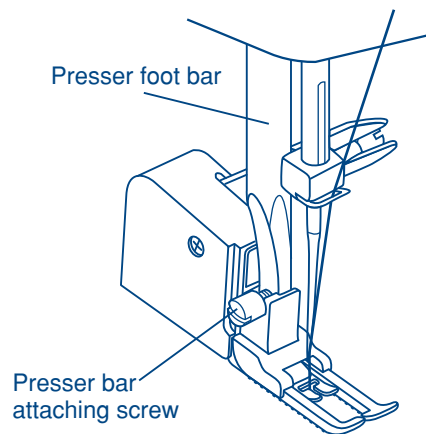

3

### Attention:

Disconnect the machine from the electricity supply by removing the plug from the mains socket. When cleaning the machine, it must always be disconnected from the electricity supply.

### Remove the needle plate:

Turn the handwheel until the needle is fully raised. Open the hinged front cover and unscrew the needle plate screw with the screw driver. (1)

### Cleaning the feed dog:

Remove the bobbin case and use the brush supplied to clean the whole area. (2)

### Cleaning and lubricating the hook:

Remove the bobbin case. Snap the two hook retaining arms (3) outwards. Remove the hook race cover (4) and the hook (5) and clean with a soft cloth. Lubricate at the points (7) (1-2 drops) with sewing machine oil. Turn the handwheel until the hook race (6) is in the left position. Replace the hook (5). Replace the hook race cover and snap back the two hook retaining arms. Insert the bobbin case and bobbin and replace the stitch plate.

### Important:

Fabric fluff and threads must be removed regularly. Your machine should be serviced at regular intervals at one of our service agencies.

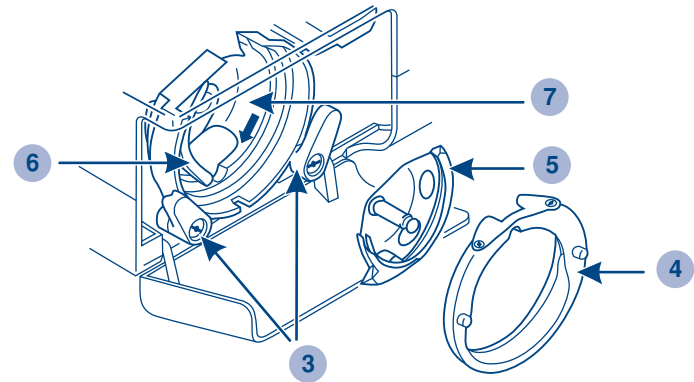
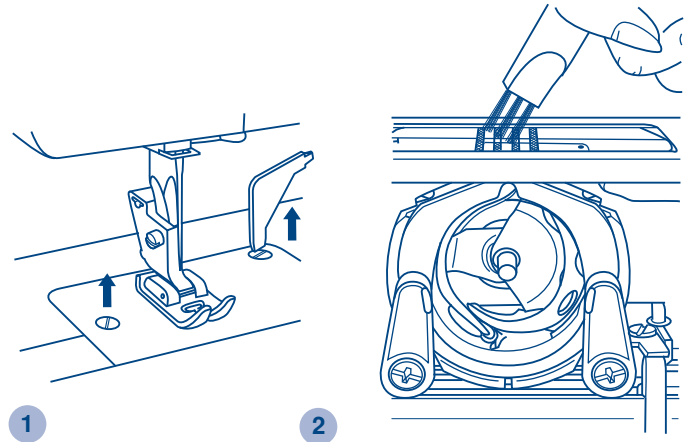

## Trouble shooting guide

| <b>Problem</b>               | <b>Cause</b>                                                                                                                                                                                                                                                                                                                     | <b>Correction</b>                                                                                                                                                                                                                                                                                                       |
|------------------------------|----------------------------------------------------------------------------------------------------------------------------------------------------------------------------------------------------------------------------------------------------------------------------------------------------------------------------------|-------------------------------------------------------------------------------------------------------------------------------------------------------------------------------------------------------------------------------------------------------------------------------------------------------------------------|
| Upper thread breaks          | <ol style="list-style-type: none"><li>1.The machine is not threaded correctly.</li><li>2.The thread tension is too tight.</li><li>3.The thread is too thick for the needle.</li><li>4.The needle is not inserted correctly.</li><li>5.The thread is round wound the spool holder pin.</li><li>6.The needle is damaged.</li></ol> | <ol style="list-style-type: none"><li>1.Rethread the machine.</li><li>2.Reduce the thread tension (lower number).</li><li>3.Select a larger needle.</li><li>4.Remove and reinsert the needle (flat side towards the back).</li><li>5.Remove the reel and wind thread onto reel.</li><li>6.Replace the needle.</li></ol> |
| Lower thread breaks          | <ol style="list-style-type: none"><li>1.The bobbin case is not inserted correctly.</li><li>2.The bobbin case is threaded wrongly.</li><li>3.The lower thread tension is too tight.</li></ol>                                                                                                                                     | <ol style="list-style-type: none"><li>1.Remove and reinsert the bobbin case and pull on the thread.<br/>The thread should pull easily.</li><li>2.Check both bobbin and bobbin case.</li><li>3.Loosen lower thread tension as described.</li></ol>                                                                       |
| Skipped stitches             | <ol style="list-style-type: none"><li>1.The needle is not inserted correctly.</li><li>2.The needle is damaged.</li><li>3.The wrong size needle has been used.</li><li>4.The foot is not attached correctly.</li></ol>                                                                                                            | <ol style="list-style-type: none"><li>1.Remove and reinsert needle(flat side towards the back).</li><li>2.Insert a new needle.</li><li>3.Choose a needle to suit the thread and fabric.</li><li>4.Check and attach correctly.</li></ol>                                                                                 |
| Needle breaks                | <ol style="list-style-type: none"><li>1.The needle is damaged.</li><li>2.The needle is not correctly inserted.</li><li>3.Wrong needle size for the fabric.</li><li>4.The wrong foot is attached.</li></ol>                                                                                                                       | <ol style="list-style-type: none"><li>1.Insert a new needle.</li><li>2.Insert the needle correctly (flat side towards the back).</li><li>3.Choose a needle to suit the thread and fabric.</li><li>4.Select the correct foot.</li></ol>                                                                                  |
| Loose stitches               | <ol style="list-style-type: none"><li>1.The machine is not correctly threaded.</li><li>2.The bobbin case is not correctly threaded.</li><li>3.Needle/ fabric/ thread combination is wrong.</li><li>4.Thread tension wrong.</li></ol>                                                                                             | <ol style="list-style-type: none"><li>1.Check the threading.</li><li>2.Thread the bobbin case as illustrated.</li><li>3.The needle size must suit the fabric and thread.</li><li>4.Correct the thread tension.</li></ol>                                                                                                |
| Seams gather or pucker       | <ol style="list-style-type: none"><li>1.The needle is too thick for the fabric.</li><li>2.The stitch length is wrongly adjusted.</li><li>3.The thread tension is too tight.</li></ol>                                                                                                                                            | <ol style="list-style-type: none"><li>1.Select a finer needle.</li><li>2.Readjust the stitch length.</li><li>3.Loosen the thread tension.</li></ol>                                                                                                                                                                     |
| Uneven stitches, uneven feed | <ol style="list-style-type: none"><li>1.Poor quality thread.</li><li>2.The bobbin case is wrongly threaded.</li><li>3.Fabric has been pulled.</li></ol>                                                                                                                                                                          | <ol style="list-style-type: none"><li>1.Select a better quality thread.</li><li>2.Remove bobbin case and retread and insert correctly.</li><li>3.Do not pull on the fabric while sewing, let it be taken up by the machine.</li></ol>                                                                                   |
| The machine is noisy         | <ol style="list-style-type: none"><li>1.The machine must be lubricated.</li><li>2.Fluff or oil have collected on the hook or needle bar.</li><li>3.Poor quality oil has been used.</li><li>4.The needle is damaged.</li></ol>                                                                                                    | <ol style="list-style-type: none"><li>1.Lubricate as described.</li><li>2.Clean the hook and feed dog as described.</li><li>3.Only use good quality sewing machine oil.</li><li>4.Replace the needle.</li></ol>                                                                                                         |
| The machine jams             | Thread is caught in the hook.                                                                                                                                                                                                                                                                                                    | Remove the upper thread and bobbin case, turn the handwheel backwards and forwards by hand and remove the thread remnants.<br>Lubricate as described.                                                                                                                                                                   |

Manufacturer: Shanghai Shanggong & Butterfly Sewing Machine Co.,Ltd.

Add.: 3rd Floor, SMPIC Building, No.669 Wusong Rd.,  
Shanghai 200080,China

Tel.: 0086-21-51078800

Fax: 0086-21-65453524

<http://www.shanggong-butterfly.com>